

# E40 Series

## Diameter ø40mm Shaft type/Hollow type/Built-in type Incremental Rotary Encoder

### ■ Features

- 12-24VDC power supply of line driver output(Line-up)
- Easy installation at narrow space
- Small moment of inertia
- Power supply : 5VDC, 12-24VDC ±5%
- Various output types

⚠ Please read "Caution for your safety" in operation manual before using.



E40S Series

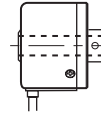

E40H Series

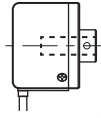

E40HB Series

### ■ Ordering information

**E40** **H** **8** **5000** **3** **N** **24**

Series	Shaft type	Hollow type	Pulse/1Revolution	Output phase	Output	Power supply	Cable
S: Shaft type H: Hollow type HB: Hollow built-in type	External 6: ø6mm 8: ø8mm	Inner 6: ø6mm 8: ø8mm 10: ø10mm 12: ø12mm	Series	2: A, B 3: A, B, Z 4: A, $\bar{A}$ , B, $\bar{B}$ 6: A, $\bar{A}$ , B, $\bar{B}$ , Z, $\bar{Z}$	T: Totem pole output N: NPN open collector output V: Voltage output L: Line driver output	5 : 5VDC ±5% 24: 12-24VDC ±5%	No mark: Cable type C: Connector cable type(※)

※Standard: E40S6-[PULSE]-3-N-24, E40H8-[PULSE]-3-N-24 ※Standard: A, B, Z  
E40HB8-[PULSE]-3-N-24

※Cable length : 250mm

### ■ Specifications

Item	Diameter ø40mm shaft/hollow shaft/hollow built-in type of incremental rotary encoder		
Resolution(P/R) <sup>*1</sup>	*1, *2, *5, 10, *12, 15, 20, 23, 25, 30, 35, 40, 45, 50, 60, 75, 100, 120, 150, 192, 200, 240, 250, 256, 300, 360, 400, 500, 512, 600, 800, 1000, 1024, 1200, 1500, 1800, 2000, 2048, 2500, 3000, 3600, 5000 (Not indicated resolution is customizable.)		
Electrical specification	Output phase	A, B, Z phase(Line driver A, $\bar{A}$ , B, $\bar{B}$ , Z, $\bar{Z}$ phase)	
	Phase difference of output	Phase difference between A and B : $\frac{T}{4} \pm \frac{T}{8}$ (T=1 cycle of A phase)	
	Control output	Totem pole output	• Low - Load current:Max. 30mA, Residual voltage : Max. 0.4VDC • High - Load current:Max. 10mA, Output voltage(Power voltage 5VDC): Min. (Power voltage-2.0)VDC, Output voltage(Power voltage 12-24VDC):Min. (Power voltage-3.0)VDC
		NPN open collector output	Load current : Max. 30mA, Residual voltage : Max. 0.4VDC
		Voltage output	Load current : Max. 10mA, Residual voltage : Max. 0.4VDC
	Response time (Rise/Fall)	Line driver output	• Low - Load current : Max. 20mA, Residual voltage : Max. 0.5VDC • High - Load current : -20mA, Output voltage(Power voltage 5VDC): Min. 2.5VDC, Output voltage(Power voltage 12-24VDC): Min. (Power voltage-3.0)VDC
		Totem pole output	Max. 1μs
		NPN open collector output	
	Voltage output		
		Line driver output	Max. 0.5μs
	Max. Response frequency	300kHz	
	Power supply	• 5VDC ±5%(Ripple P-P : Max. 5%) • 12-24VDC ±5%(Ripple P-P : Max. 5%)	
	Current consumption	Max. 80mA(disconnection of the load), Line driver output : Max. 50mA(disconnection of the load)	
Insulation resistance	Min. 100MΩ(at 500VDC megger between all terminals and case)		
Dielectric strength	750VAC 50/60Hz for 1 minute(Between all terminals and case)		
Connection	Cable type, 250mm connector cable type		
Mechanical specification	Starting torque	Shaft type : Max. 40gf·cm(0.004N·m), Hole type : Max. 50gf·cm(0.005N·m)	
	Moment of inertia	Max. 40g·cm <sup>2</sup> (4×10 <sup>-6</sup> kg·m <sup>2</sup> )	
	Shaft loading	Radial : Max. 2kgf, Thrust : Max. 1kgf	
	Max. allowable revolution <sup>*2</sup>	5000rpm	
Vibration	1.5mm amplitude or 300m/s <sup>2</sup> at frequency of 10 to 55Hz(for 1 min.) in each of X, Y, Z directions for 2 hours		
Shock	Approx. Max. 50G		
Environment	Ambient temperature	-10 to 70°C, storage : -25 to 85°C	
	Ambient humidity	35 to 85%RH, storage : 35 to 90%RH	
Protection	IP50(IEC standard) ※Option type is available for IP64 (IEC standard).		
Cable	ø5, 5-wire, Length : 2m, Shield cable(Line driver output : ø5, 8-wire) (AWG24, Core diameter: 0.08, Number of cores: 40, Insulator out diameter: ø1)		
Accessory	• Shaft type : ø6mm coupling standard, ø8mm coupling(Sold separately) • Hole type : Bracket		
Approval	CE (Except line driver output)		
Unit weight	Approx. 160g		

※1: 'v' pulse is only for A, B phase(Line Driver output is for A,  $\bar{A}$ , B,  $\bar{B}$  phase)

※2: Make sure that. Max response revolution should be lower than or equal to max. allowable revolution when selecting the resolution.

$$[\text{Max. response revolution}(\text{rpm})] = \frac{\text{Max. response frequency}}{\text{Resolution}} \times 60 \text{ [sec]}$$

※Environment resistance is rated at no freezing or condensation.

# Incremental ø40mm Shaft/Hollow Shaft/Built-in type

## Control output diagram

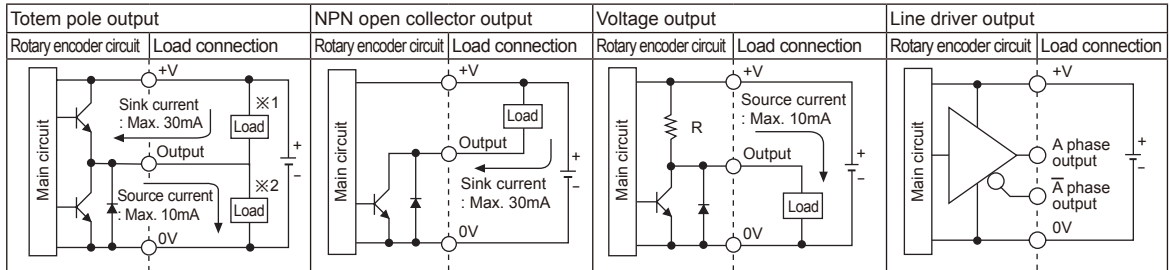

- Totem pole output type can be used for NPN open collector output type(※1) or Voltage output type(※2).
- All output circuits of A, B, Z phase are the same. (Line driver output is A,  $\bar{A}$ , B,  $\bar{B}$ , Z,  $\bar{Z}$ )

## Output waveform

- Totem pole output / NPN open collector output / Voltage output

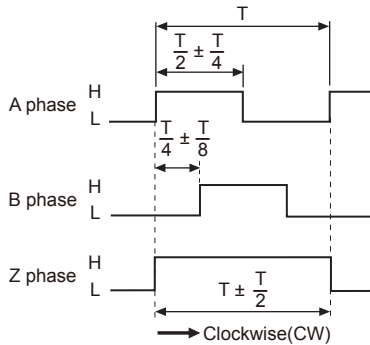

- ※Z phase output is option.
- ※CW : Right turn as from the shaft.

- Line driver output

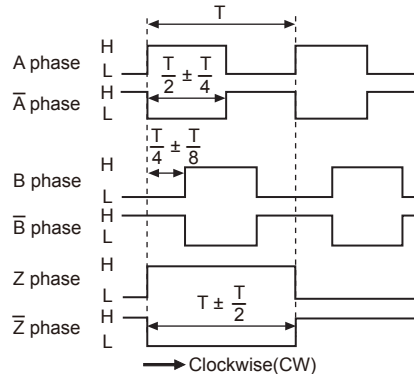

## Connections

### ◎ Cable type

- Totem pole output / NPN open collector output / Voltage output

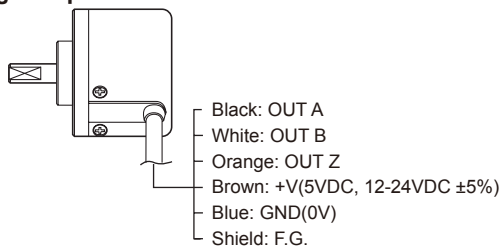

- ※Unused wires must be insulated.
- ※The metal case and shield wire of encoder should be grounded(F.G.).

- Line driver output

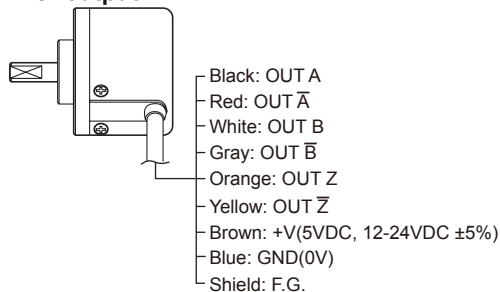

### ◎ Connector cable type

- Totem pole output / NPN open collector output / Voltage output
- Line driver output



Totem pole output/ NPN open collector output/ Voltage output			Line driver output		
Pin No	Function	Cable color	Pin No	Function	Cable color
①	OUT A	Black	①	OUT A	Black
②	OUT B	White	②	OUT $\bar{A}$	Red
③	OUT Z	Orange	③	+V	Brown
④	+V	Brown	④	GND	Blue
⑤	GND	Blue	⑤	OUT B	White
⑥	F.G.	Shield	⑥	OUT $\bar{B}$	Gray
			⑦	OUT Z	Orange
			⑧	OUT $\bar{Z}$	Yellow
			⑨	F.G.	Shield

- ※F.G.(Field Ground): It should be grounded separately.

(A) Photo electric sensor

(B) Fiber optic sensor

(C) Door/Area sensor

(D) Proximity sensor

(E) Pressure sensor

(F) Rotary encoder

(G) Connector/Socket

(H) Temp. controller

(I) SSR/ Power controller

(J) Counter

(K) Timer

(L) Panel meter

(M) Tacho/ Speed/ Pulse meter

(N) Display unit

(O) Sensor controller

(P) Switching mode power supply

(Q) Stepper motor & Driver&Controller

(R) Graphic/ Logic panel

(S) Field network device

(T) Software

(U) Other

# E40 Series

## ■ Dimensions

(unit: mm)

### ◎ Cable type

#### ● Shaft type

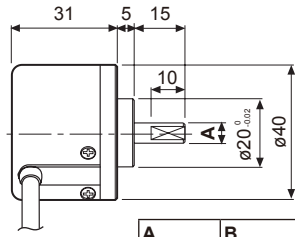
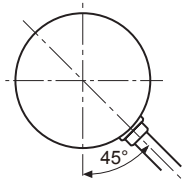

A	B
ø6 <sup>-0.01</sup> <sub>-0.015</sub>	5
ø8 <sup>-0.01</sup> <sub>-0.02</sub>	7

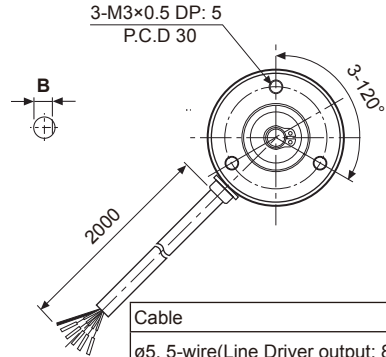

Cable  
ø5, 5-wire(Line Driver output: 8-wire),  
Length:2000, Shield cable

### ● Hollow shaft / Hollow shaft built-in type

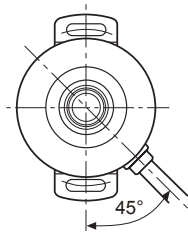

E40H

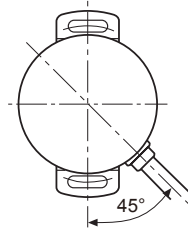
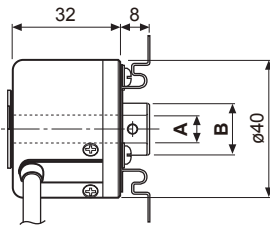

E40HB

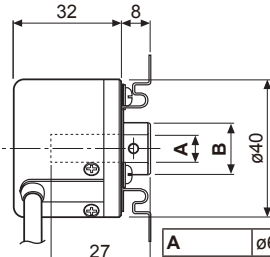

A	ø6	ø8	ø10	ø12
B	ø15	ø17		
Tolerance	+0.015 0			

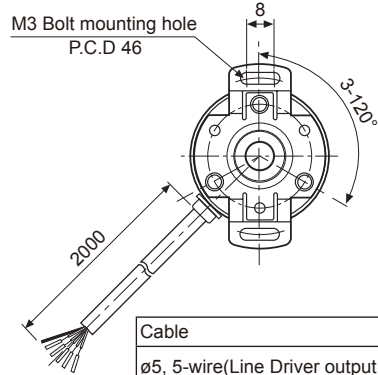

Cable  
ø5, 5-wire(Line Driver output: 8-wire),  
Length: 2000, Shield cable

### ◎ Connector cable type

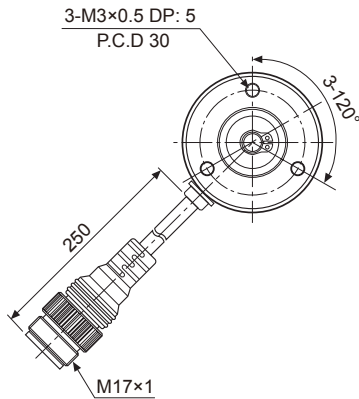

※Connector cable is customizable and refer to the G-10 for specifications.

### ● Bracket(E40H, E40HB)

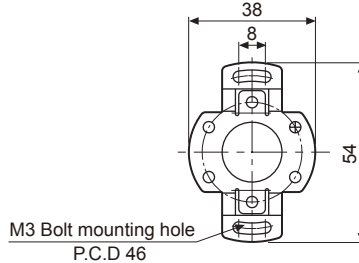

### ● Coupling(E40S)

#### ● ø6 Coupling

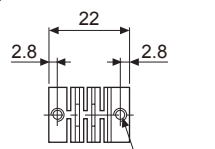
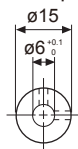

#### ● ø8 Coupling

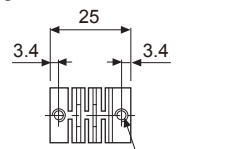
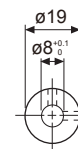

- Parallel misalignment : Max. 0.25mm
- Angular misalignment: Max. 5°
- End-play: Max. 0.2mm

- ※For parallel misalignment, angular misalignment, end-play terms, refer to the F-78 page.
- ※For flexible coupling(ERB Series) information, refer to the F-71 page.